

# Cableprint CP 4R

## High-Speed-Printer

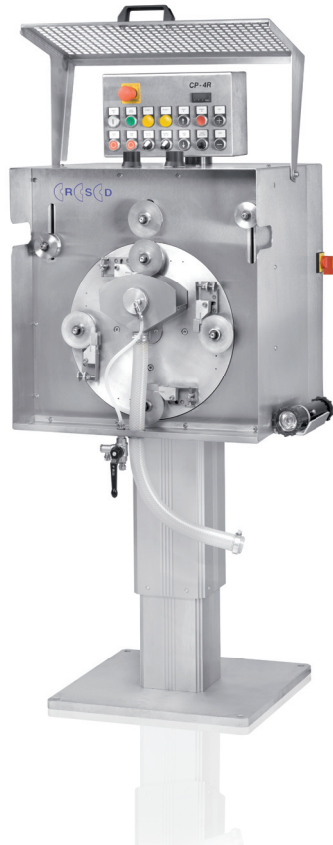

Type of machine	CP4R-81
Type of printing	direct printing
Drive	electronically controlled drive
Automatic synchronization with line	yes
Number of printing stations	4
Printing direction	l. → r. / r. → l.
Maximum printing diameter	Ø 0,8 mm - 25 mm (.031 - 1")
Lift column electronically adjustable	yes
Print height adjustment	900 mm - 1200 mm (35" - 47")
Maximum printing speed	1500 m/min (4800 fpm)
Printing wheel diameter	Ø 86 mm (3.386")
Mounting hole diameter	12,7 mm (.500")
Ink reservoir	0,5 - 2 L (.13 - .53 GAL)
Suitable for flat printing wheels	yes
Suitable for concave printing wheels	yes
Suitable for embossing/indenting wheels	yes
Printing simulator	yes
Inline-stroboscope lamp(synchronized)	optional
Viscosity control system	optional
Viscosity unit for double ink pump system	optional
Second ink pump unit for quick ink change	optional
Rail Mounted	optional
Power Supply	400 V, 50 Hz, 3 Ph
Built-in transformer	optional
Weight	approx. 155 kg (345 LBS)

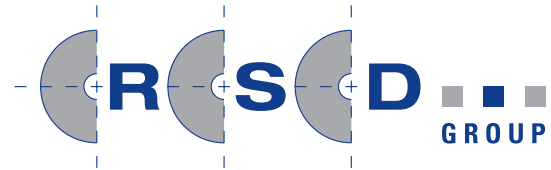
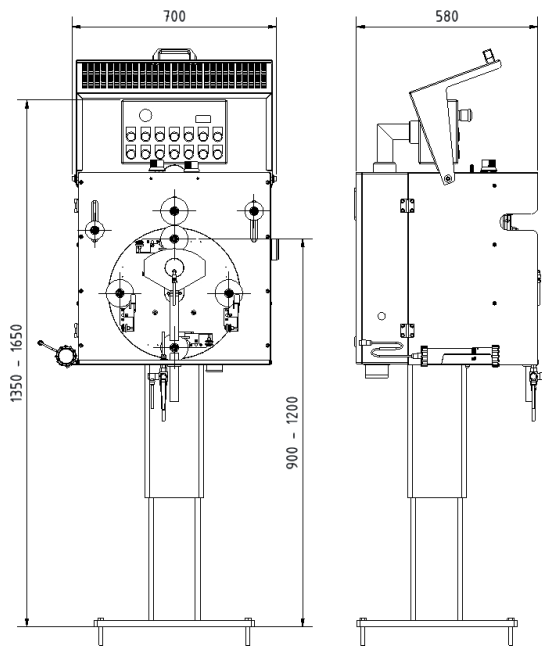

- automatic cable printing machine with electronically controlled print wheel drive
- automatic print wheel change, without production stop
- drive system allows printing speeds up to 1500 m/min. (4800 fpm)
- particularly suitable for quick changes of text or numeric printing.
- high speed wiper system
- synchronized inline-stroboscope provides an easy method for examining the printing process

### RSD Group

W Gillies Technologies, LLC • 250 Barber Ave • PO Box 60329 • Worcester, MA 01606 USA

Phone: +01 508-852-2502 Fax: +01 508-852-6453 E-mail: sales@wgillies.com

Web: www.wgillies.com www.rsdsdtechnik.com